



# Diode Failure Detector



The Stamford Diode Failure Detector (DFD) is suitable for use with all Stamford Generators. It senses the level of ripple current in the exciter output to provide indication of a failed diode, either short or open circuit.

Frequently demanded in the oil and gas industries this warning device is increasingly required by many other users who recognise the benefits of early failure warning. The DFD has a delayed response of 7 second to avoid 'nuisance trip' signals before indicating the fault via voltage free changeover contacts.

By receiving a quick warning of a single failed diode the user may arrange shutdown (manually or automatically) of the engine. Alternatively on receipt of the warning, the exciter field current or voltage can be monitored, reducing load if necessary, to ensure that recommended levels are not exceeded. In this way the generator set can continue to provide emergency supplies until a planned controlled shutdown when the necessary diode replacements can be made.

Of course a Stamford Series 3 separately excited system offers the safety of over-excitation protection within the AVR. But the DFD actually diagnoses if the fault lies with the rectifier diodes, and so encourages the best course of action.

- Reliable solid-state warning of rotating rectifier diode failure.
- Jumper Selectable D.C. (12 or 24V) or AC (120 or 240V).
- Simple connections to generator.
- Simple test facility.

## TECHNICAL SPECIFICATION

<b>SUPPLY VOLTAGE</b>	DC 12-28V AC 100 - 140V or 200 - 280V
<b>SUPPLY CURRENT</b>	DC 0.2A max
<b>OUTPUT</b>	Voltage Free Contacts Isolation 2kV 1 Pole Changeover Rating 5A @ 30Vdc/240 ac
<b>RESPONSE TIME</b>	(Approx) 7 seconds
<b>ENVIRONMENTAL</b>	
<b>Operating temp</b>	- 40°C to + 70°C
<b>Storage temp</b>	- 55°C to + 80°C
<b>Humidity</b>	0 to 60°C 95%RH
<b>Vibration</b>	20 - 100 Hz 30mm/seconds 100 Hz - 2kHz 2.0g

Not suitable for mounting in generator terminal box. Switchboard or bedplate mounting recommended.

## GENERAL ARRANGEMENT DIAGRAM

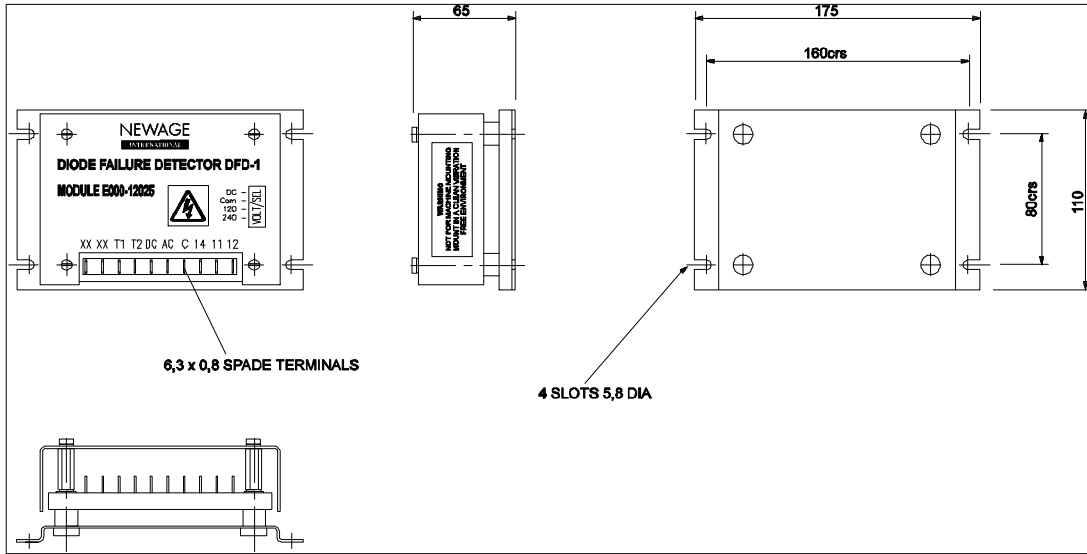

## CONNECTION DIAGRAM

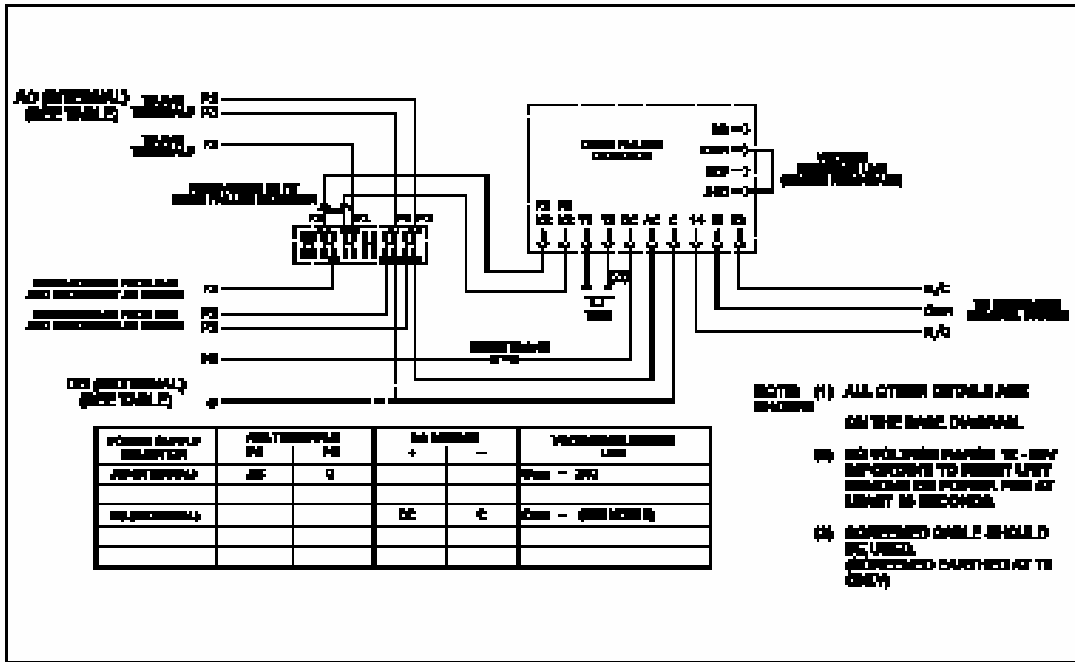

Barnack Road • Stamford • Lincolnshire • PE9 2NB  
 Tel: 00 44 (0)1780 484000 • Fax: 00 44 (0)1780 484100  
 Website: www.newage-avkseg.com