

Excitation Loss Module

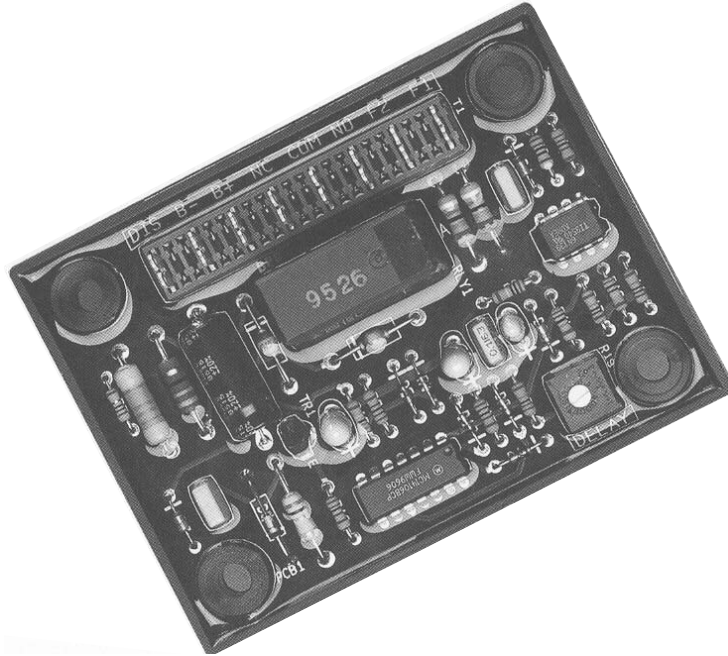

A loss of generator excitation during parallel operation will result in heavy circulating currents, pole-slipping (loss of synchronisation) and torque/current surges and oscillation. The Stamford Excitation Loss Module monitors the generator AVR output and signals any sustained interruption to an integral relay to initiate an indication/alarm.

The ELM, which has been specially designed for use with all the Company's AVR's, is powered independently from the engine battery at 12V or 24V. It operates by detecting the absence of the characteristic 'rectifier ripple' in the exciter field voltage. An optical isolator used to ensure complete electrical isolation between the exciter field circuit and the engine battery system. Any loss of AVR output is recognised immediately by the monitoring circuit, and if the interruption persists for more than about a second the module output energises an integral relay. The changeover contacts can either provide remote indication of the excitation failure or operate any other relay-fed protective device. The system incorporates a time delay to prevent spurious tripping on transients and an overrideable eight-second engine-start lock-out.

Robust and reliable solid-state electronics.
Independently powered from engine battery.
Power supply completely isolated from exciter field.
Engine-start lock-out time delay.

SPECIFICATION

There are two versions of the ELM; one for 12V engine battery systems and one for 24V.

SENSING INPUT

Voltage 0-150 Vdc
Input resistance 100 k ohms
Sensitivity 50 v peak

POWER INPUT

Voltage 10-14 Vdc (ELM 12V)
20-28 Vdc (ELM 24V)
Current (standby) 25 ma max all models
Relay on 150 ma max (ELM 12V)
60 ma max (ELM 24V)

OUTPUT

Single pole changeover relay
Rating 5A @ 30 Vdc
5A @ 240 Vdc
Power dissipation 3 Watts maximum

TIME DELAYS

Response time 1.5-2 seconds
Power up delay 8-15 seconds

ENVIRONMENTAL

Vibration 20-100 Hz 30 mm/sec
100 Hz - 2 kHz 2g
Relative humidity 95%
Operating temperature -40 to +70°C
Storage temperature -55 to +80°C

GENERAL ARRANGEMENT DIAGRAM

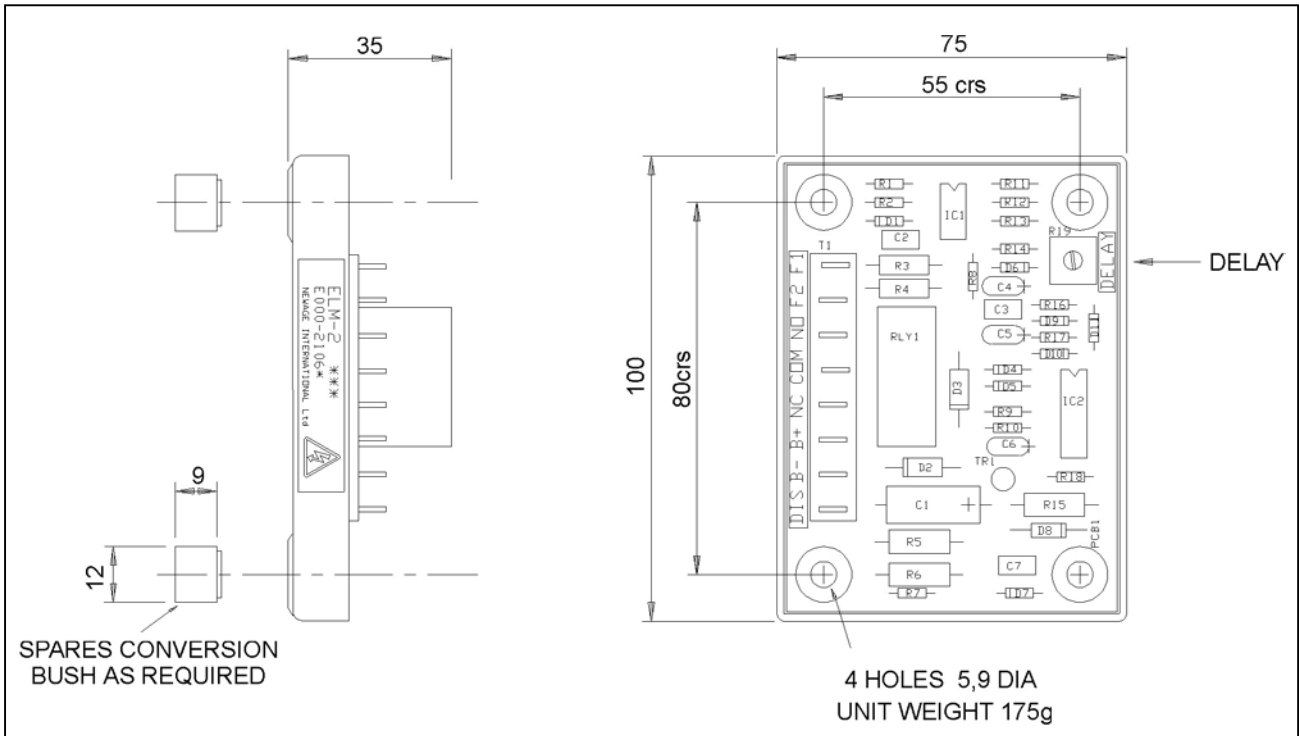

Not suitable for mounting in generator terminal box. Switchboard or bedplate mounting recommended.

CONNECTION DIAGRAM

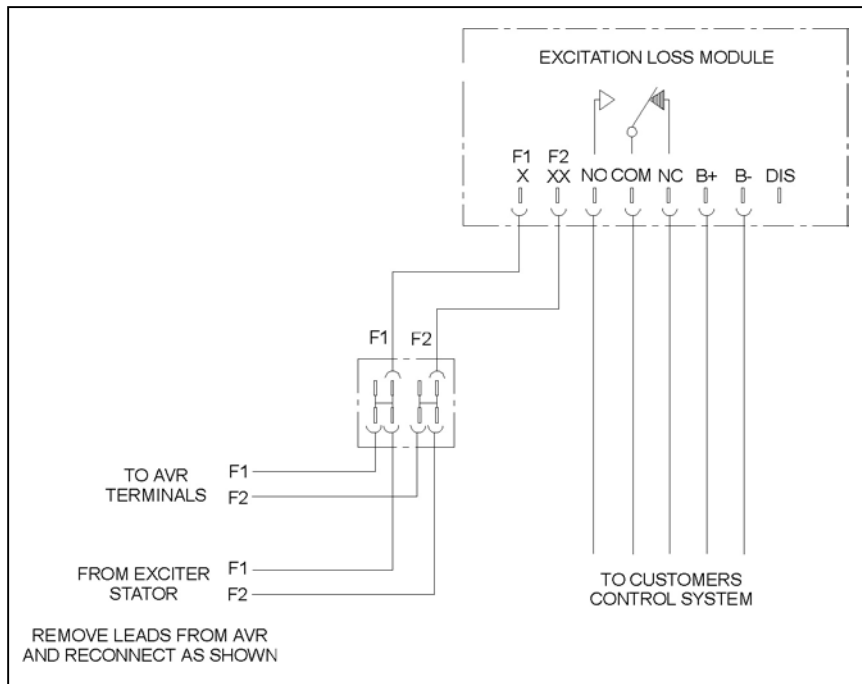

PO Box 17 • Barnack Road • Stamford • Lincolnshire • PE9 2NB

Tel: 00 44 (0)1780 484000 • Fax: 00 44 (0)1780 484100

Website: www.newage-avkseg.com