

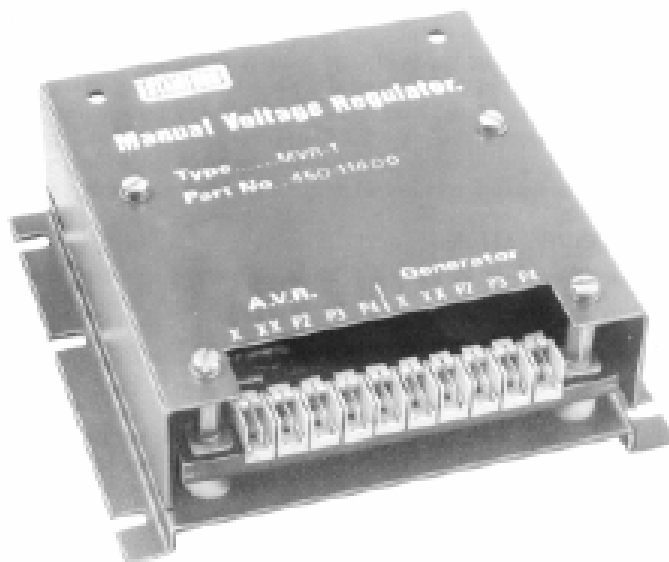

# Manual Voltage Regulator



An 'emergency' hand-controlled excitation system can constitute an operational advantage for an a.c. generator. Although manual control in the event of AVR failure is not normally very practicable, it can nevertheless be usefully exploited to permit a hand-controlled machine to 'trail' in parallel with a master generator with a healthy AVR. Manual control can also be useful for the provision of a controlled level of short circuit current (for drying-out windings or setting protective devices); for the 'frequency' starting of relatively large motors (where an electrically connected generator and motor are run up together from rest); for the 'dynamometer' loading of motors or engines; and for the control of static loads (e.g. for variable intensity lighting).

The Stamford Manual Voltage Regulator (MVR) is available with the permanent-magnet pilot excitation system. Powered independently from the p.m. pilot, the MVR is a manually-set but automatically-controlled constant-current system whose output is independent of a generator voltage or frequency.

This independence provides both flexibility and operational stability, no interaction between generator voltage and exciter field current, and both reliable build-up and a sustained short circuit-current capability are inherently available.

- Robust and reliable solid-state electronics.
- Manually-set automatic field current control.
- Dependable power feed from p.m. pilot exciter.

The system offers three switch-selectable operational modes as follows: Manual, with an operator-set field current automatically maintained; OFF, with zero field current; and Auto, with the normal AVR in circuit and maintaining a pre-set terminal voltage. A switched mode change with the generator running will not damage the MVR or the AVR, although the effects of the change on the generator and on any connected load must of course be monitored. The standard output limits are 0.25A minimum and 2.0A maximum. An external lamp or relay can if required be connected across two of the terminals of an interconnected AVR to indicate that the unit is switched into the AVR operating mode.

## SPECIFICATION

<b>INPUT</b> (from p.m. pilot)	150-220 V 67-120 Hz (depending on speed) three-phase
<b>REGULATED OUTPUT</b>	0.25-2.0 Ad.c. into 20 ohms minimum
<b>POWER DISSIPATION</b>	6 watts maximum

## ENVIRONMENTAL

Vibration	20-100 Hz	30 mm/sec
	100 Hz - 2 kHz	2g
Relative humidity	95%	
Operating temperature	-40 to +70°C	
Storage temperature	-55 to +80°C	

## GENERAL ARRANGEMENT DIAGRAM

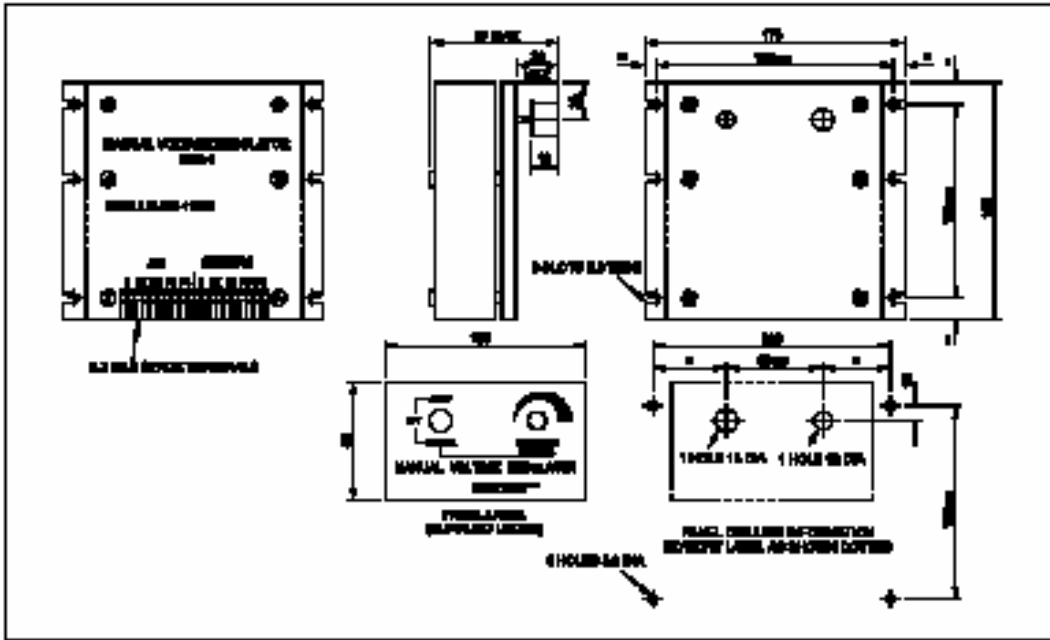

Not suitable for mounting in generator terminal box. Switchboard or bedplate mounting recommendable.

## CONNECTION DIAGRAM

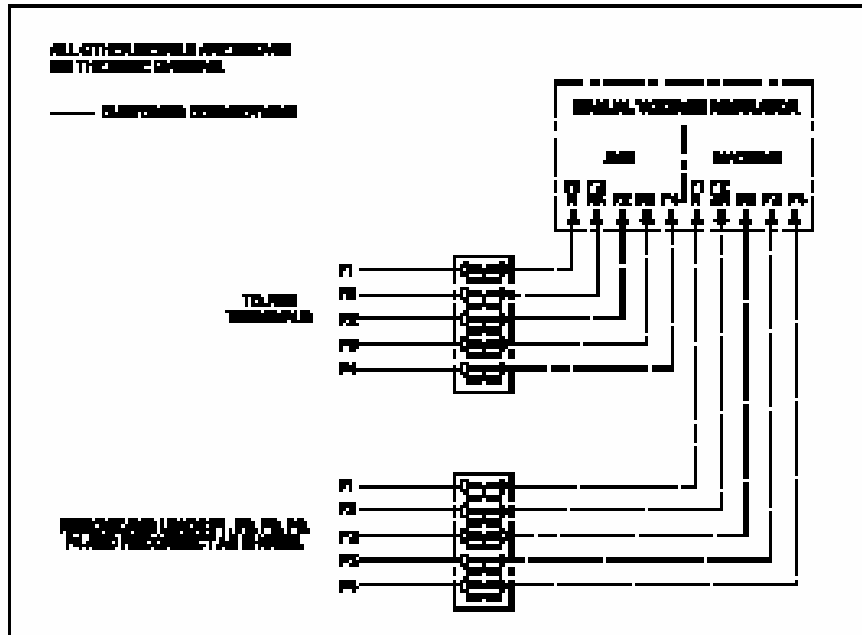

Barnack Road • Stamford • Lincolnshire • PE9 2NB  
 Tel: 00 44 (0)1780 484000 • Fax: 00 44 (0)1780 484100  
 Website: [www.newage-avkseg.com](http://www.newage-avkseg.com)