

NOTES:-

SHAFT STIFFNESS:-

THE STIFFNESS OF THE SHAFT BETWEEN THE MAIN ROTOR CORE ϕ AND THE SHAFT FACE 'A' IS 4.0930×10^6 kgcm/radian (STIFFENING EFFECT OF MAIN ROTOR CORE IS NOT INCLUDED IN THIS FIGURE)

SHAFT MATERIAL:-

STEEL - C40E TO BSEN 10083-2 2006 (APPROVED BY MARINE AUTHORITIES WHEN APPROPRIATE) MAXIMUM RECOMMENDED VIBRATORY STRESS LEVEL IN THE SHAFT IS 34.47×10^6 N/m² FOR SPEED RANGE OF 0.95 TO 1.1 X NOMINAL SPEED AND 68.94×10^6 N/m² FOR RUN THROUGH CONDITIONS, FOR INDUSTRIAL MACHINES.

FOR MARINE AUTHORITIES, THEIR APPROPRIATE RULES WILL APPLY.

CUMMINS GENERATOR TECHNOLOGIES LTD SHOULD BE NOTIFIED OF ANY ROTORS NOT COMPLYING WITH THESE RULES. CUMMINS GENERATOR TECHNOLOGIES LTD BALANCE ROTORS TO COMPLY WITH INTERNATIONAL STD BS ISO 1940 PARTS 1 AND 2 . BALANCE GRADE 2.5

FOR UNBALANCED MAGNETIC PULL (U.M.P.) REFER BACK TO THE FACTORY.

ADAPTOR SAE No.	COUPLING SAE No.	COUPLING DIMENSIONS		MASS OF DISC (kg) (1 X 3mm THICK)	MASS OF SHAFT SPACER (kg)	MASS OF PRESSURE PLATE (kg)	TOTAL MASS OF COUPLING ASSEMBLY (kg)	COUPLING STIFFNESS (kgcm/rad)	COUPLING DISC WR^2 (kgm ²)
		ØXX mm	YY mm						
4/5	6 1/2	215.8	10	0.850	0.233	0.069	1.152	13.955×10^6	0.0049
4/5	7 1/2	241.2	10	1.069	0.233	0.069	1.371	13.835×10^6	0.0079
3/4/5	8	263.5	41.8	1.275	0.974	0.069	2.318	13.747×10^6	0.0111
2/3/4	10	314.2	33.6	1.819	0.783	0.069	2.671	13.616×10^6	0.0225
2/3	11 1/2	352.3	19.4	2.287	0.452	0.069	2.808	13.555×10^6	0.0355

COMPONENT	MASS (kg)	WR^2 (kgm ²)
SHAFT	8.1439	0.0032
FAN	0.976	0.0067
MAIN ROTOR	26.750	0.1274
EXCITER ROTOR	4.300	0.0170
TOTAL WITHOUT EBG ROTOR	40.170	0.1544
EBG ROTOR	1.701	0.0017
TOTAL WITH EBG ROTOR	41.871	0.1560

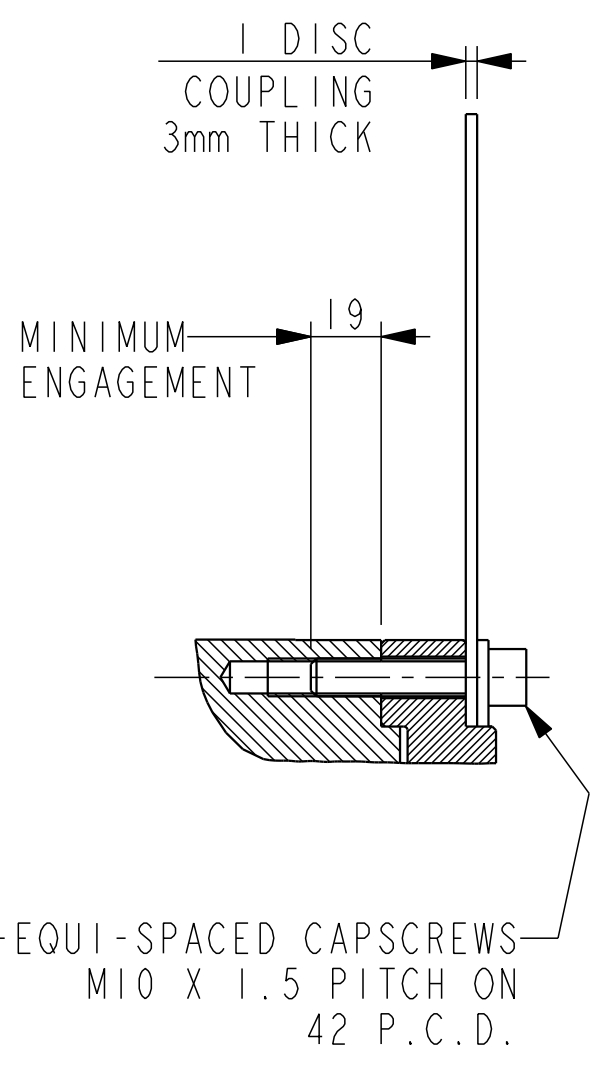

CONVERSION FACTORS		
TO CONVERT	TO	DIVIDE BY
kg	lb	0.453592
kgm ²	lbft ²	0.04214
kgcm/rad	lbin/rad	1.1521246
N/m ²	lbf/in ²	6894.76

CONFIDENTIAL PROPERTY OF CUMMINS GENERATOR TECHNOLOGIES LTD.

PI4D ONE BEARING MOMENTS OF INERTIA AND SHAFT DETAILS

MATERIAL PROPS -	DIMENSIONS IN MILLIMETRES (MM) AT 20°C	PROJECTION		
FINISH SPEC -		WEIGHT =		
GEOMETRY SPEC -		DRAWN	BSR	19/04/07
ASSEMBLY SPEC -		CHECKED	DSG	22/05/07
PERFORMANCE SPEC -		APPROVED	DPC	22/05/07
QUALITY SPEC -	UNLIMITED DIMS ± --			

SCALE 3:10	MATERIAL --
DRG. SIZE C	CASTING No -
REL. PHASE P	PART No L15-13181
PRO/ENGINEER	ISSUE A
SHEET 1 OF 1 SHEETS	

MOD.	ISSUE	DRAWN	DATE	MODIFICATION
4-8440-50	A	BSR	19/04/07	ORIGINAL ISSUE